

HELLA
VALUEFIT

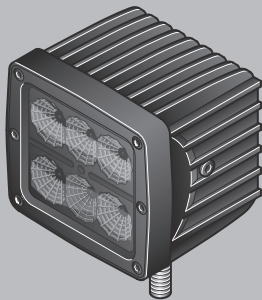

MONTAGEANLEITUNG

CUBE 1000 MIT U-BÜGEL

INSTALLATION INSTRUCTION

CUBE 1000 WITH U-BRACKET

INSTRUCTIONS DE MONTAGE

CUBE 1000 AVEC SUPPORT EN U

INSTRUCCIONES DE MONTAJE

CUBE 1000 CON SOPORTE EN U

ISTRUZIONI DI MONTAGGIO

CUBE 1000 CON STAFFA A U

INSTRUÇÕES DE INSTALAÇÃO

CUBE 1000 COM U-BRACKET

KURULUM TALIMATLARI

CUBE 1000 U BRACKETLI

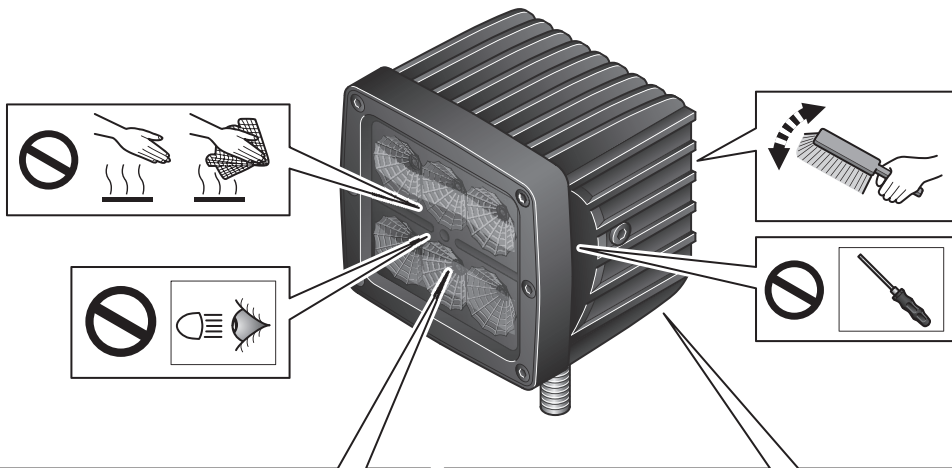

30 cm



Scheinwerfer darf nicht abgedeckt werden.
Headlamp must not be covered.
Ne pas recouvrir le projecteur.
El faro no deberá taparse.
Non coprire il faro.
O farol não deve ser coberto.
Far kapatılmamalıdır.

DE PRODUKTHAFTUNG

- Es sind die nationalen Anbau-, Einbau- und Betriebsvorschriften zu beachten und einzuhalten.
- Lesen Sie bitte vor Gebrauch des Gerätes alle beigelegten Anleitungen und Sicherheits-hinweise.
- Im Zuge von Produktverbesserung behalten wir uns technische und optische Änderungen vor.
- Verwenden Sie nur die Originalersatzteile bzw. nur Ersatzteile die von HELLA freigegeben sind.
- Bei Fragen oder Einbauproblemen, wenden Sie sich bitte an den HELLA Kundendienst, den Großhändler oder an Ihre Werkstatt.
- Weitere Informationen finden Sie auch auf unserer Internetseite (www.hella.com/techworld)

EN PRODUCT LIABILITY

- National mounting, fitting and operating regulations must be heeded and kept.
- Please read all the instructions and safety notes included before using the device.
- We reserve the right to make technical and optical modifications within the course of product improvement.
- Only use original spare parts or spare parts approved by HELLA.
- If you have any questions or problems with the installation, please contact HELLA Customer Services, a wholesaler or your garage.
- Further information is available on our website (www.hella.com/techworld)

FR RESPONSABILITÉ PRODUIT

- Les prescriptions nationales en matière de montage et de service doivent être observées et respectées.
- Avant d'utiliser l'appareil lire toutes les instructions de montage et de service fournies ainsi que les conseils de sécurité.
- Dans le cadre de l'amélioration continue de nos produits, nous nous réservons le droit de réaliser des modifications sur les plans technique et optique.
- Utilisez uniquement des pièces d'origine ou des pièces de rechange validées par HELLA.
- Pour toute question ou en cas de problèmes de montage, veuillez contacter le S.A.V. ou le distributeur HELLA ou bien vous adresser à votre garagiste.
- Vous trouverez également des informations complémentaires sur notre site Internet (www.hella.com/techworld)

ES RESPONSABILIDAD CIVIL POR PRODUCTOS DEFECTUOSOS

- Tienen que observarse y cumplirse con las prescripciones nacionales sobre construcciones anexas, de montaje y de funcionamiento.
- Rogamos que antes de usar el aparato lean todas las instrucciones y advertencias sobre la seguridad adjuntas.
- En aras de la mejora de los productos, nos reservamos el derecho de hacer modificaciones técnicas y ópticas.
- Use sólo recambios originales o bien sólo recambios autorizados por HELLA.
- En caso de dudas o preguntas a la hora del montaje, llame al servicio de atención al cliente de HELLA o diríjase a su Distribuidor o Taller.
- Encontrará más información en nuestra página web (www.hella.com/techworld)

IT RESPONSABILITÀ PER IL PRODOTTO

- Si devono rispettare tutte le normative nazionali di attacco, montaggio e funzionamento.
- Prima di usare l'apparecchio, legga per favore tutte le istruzioni e le avvertenze di sicurezza allegate.
- Nell'ambito del perfezionamento del prodotto, ci riserviamo modifiche tecniche ed estetiche.
- Utilizzare solo pezzi di ricambio originali risp. pezzi autorizzati dalla HELLA.
- Per eventuali domande o problemi di installazione contattare l'Assistenza Clienti HELLA, il grossista o rivolgersi alla propria officina.
- Ulteriori informazioni sono disponibili anche sul nostro sito web (www.hella.com/techworld)

PT RESPONSABILIDADE DO PRODUTO

- Devem ser cumpridas as prescrições nacionais que visam a montagem e a operação.
- Antes de utilizar o aparelho deve-se ler todas as instruções e avisos de segurança fornecidos.
- Reservamo-nos o direito de alterações técnicas e óticas no âmbito dos processos de melhoramento e de aperfeiçoamento dos produtos.
- Utilizar exclusivamente peças sobressalentes originais ou peças sobressalentes que tenham sido autorizadas e validadas pela HELLA.
- Em caso de dúvidas ou problemas durante a montagem, entre em contato com o distribuidor autorizado mais próximo.
- Para mais informações, acesse nosso site (www.hella.com/techworld)

TR**ÜRÜN SORUMLULUĐU**

- Dıřa montaj, ie montaj ve iřletime iliřkin ulusal ynetmelikler dikkate alınmalı ve bunlara uyulmalıdır.
- Cihazı kullanmaya bařlamadan nce, birlikte verilen tm kılavuzları ve gvenlik uyarılarını ltfen okuyun.
- rn geliřtirme alıřmaları kapsamında, teknik ve grsel deėiřiklikler yapma hakkımız saklıdır.
- Yalnız orijinal yedek paralar veya HELLA tarafından onaylanmış olan yedek paralar kullanın.
- Sorularınız olması durumunda veya montaj problemlerinde, toptancılara iin HELLA mřteri hizmetlerini telefonla arayın veya yetkili servise bařvurun.
- Daha fazla bilgiye web sitemizden ulařabilirsiniz (www.hella.com/techworld)

Zeichenerklärung
Explanation symbols
Explication des symboles

Aclaración de símbolos
Legenda
Símbolos de explicação

Simgelerin açıklamaları



- (DE) Richtig
 (EN) Correct
 (FR) Correct
 (ES) Correcto
 (IT) Giusto
 (PT) Correto
 (TR) Doğru



- (DE) Falsch
 (EN) Incorrect
 (FR) Incorrect
 (ES) Erróneo
 (IT) Sbagliato
 (PT) Incorreto
 (TR) Yanlış



- (DE) Positionspfeil
 (EN) Location/Position Arrow
 (FR) Flèche de Position
 (ES) Flecha de posición
 (IT) Freccia di posizione
 (PT) Seta de localização/posição
 (TR) Yer/Konum Oku



- (DE) Bewegungspfeil
 (EN) Movement Arrow
 (FR) Flèche indiquant sens du vouvement
 (ES) Flecha de movimiento
 (IT) Freccia di movimento
 (PT) Seta de movimento
 (TR) Hareket Oku



- (DE) Achtung
 (EN) Warning
 (FR) Attention
 (ES) Atención
 (IT) Attenzione
 (PT) Aviso
 (TR) Uyarı



- (DE) Abklemmen
 (EN) Disconnect
 (FR) Déconnecter
 (ES) Desconectar
 (IT) Staccare
 (PT) Desligar
 (TR) Bağlantıyı Kes



- (DE) Verbinden
 (EN) Connect
 (FR) Connecter
 (ES) Conectar
 (IT) Collegare
 (PT) Ligar
 (TR) Bağlan



- (DE) Siehe
 (EN) Look/See
 (FR) Voir
 (ES) Ver
 (IT) Vedere
 (PT) Ver
 (TR) Bak/Gör



- (DE) Warnung
 (EN) Warning
 (FR) Attention
 (ES) Advertencia
 (IT) Avvertimento
 (PT) Advertência
 (TR) Uyarı

Lieferumfang
Scope of delivery
Fourniture

357 206-011
357 206-041

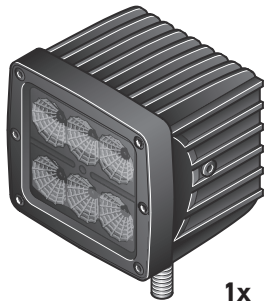

Alcance de suministro
Contenuto della confezione
Escopo de fornecimento

357 206-031
357 206-051

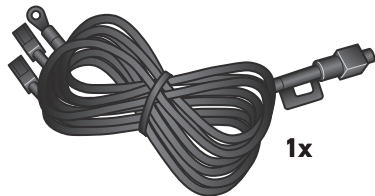
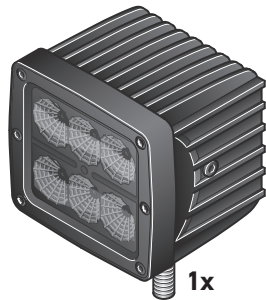
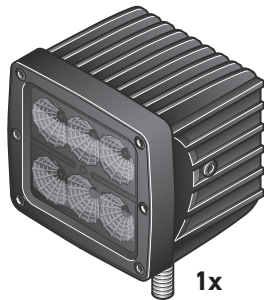

Benötigte Montagewerkzeuge
Installation tools required
Outillage de montage requis

Herramientas de montaje necesarias
Attrezzi necessari per il montaggio
Ferramentas de instalação necessárias

Kurulum aletleri gereklidir

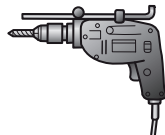
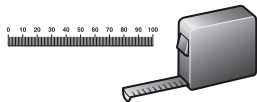

13



Ø8,5 mm



Montage
Mounting
Montage Général

Montaje
Montaggio
Montagem

Montaj

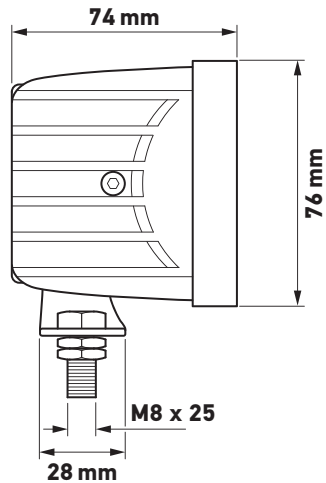
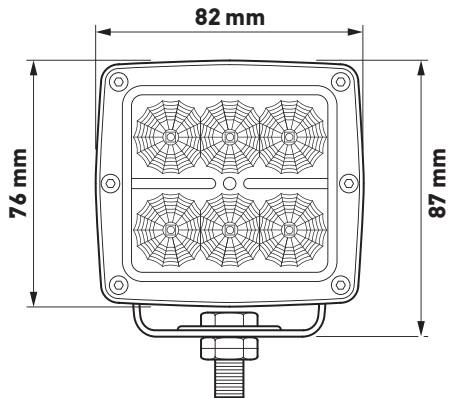

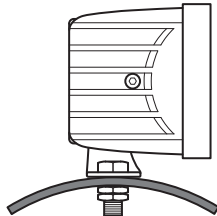
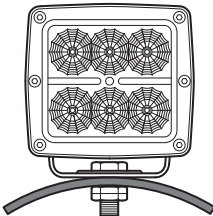
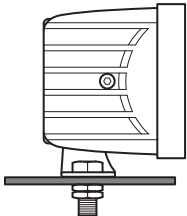
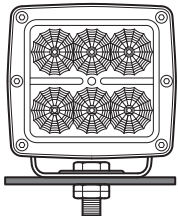
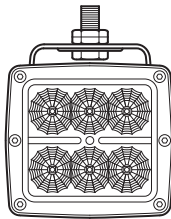
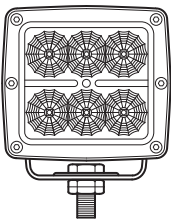

$180^\circ \pm 5^\circ$

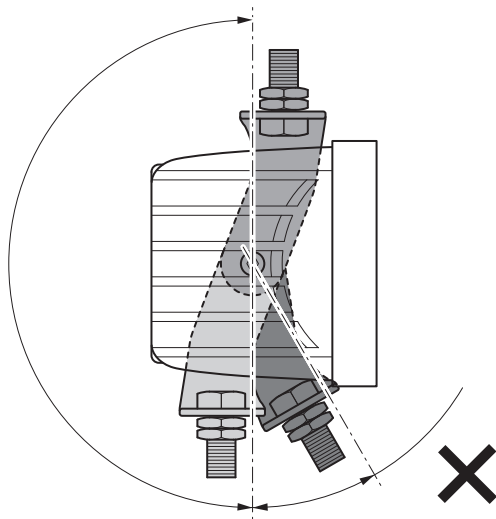

$30^\circ \pm 5^\circ$



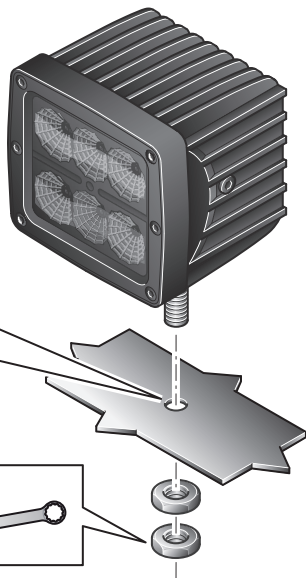
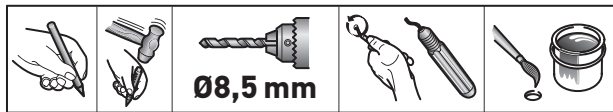

Elektrischer Anschluss
Electrical connection
Branchement électrique

Conexión eléctrica
Collegamento elettrico
Ligação elétrica

Elektrik bağlantısı

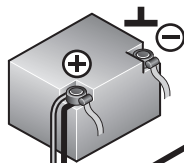
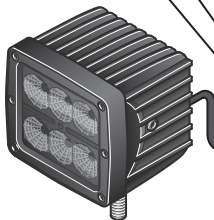
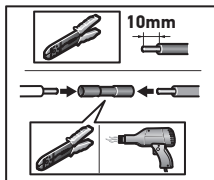

12 V	10A
24 V	5A

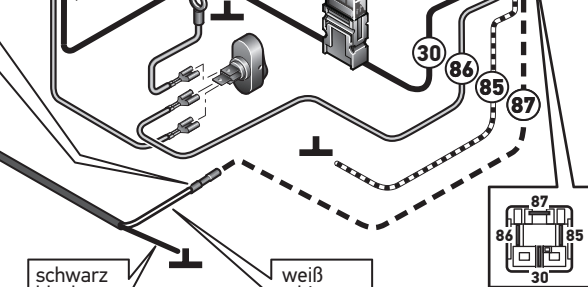

- (DE)** Installation Beispiel
- (EN)** Example of installation
- (FR)** Exemple d'installation
- (ES)** Ejemplo de instalación
- (IT)** Esempio di installazione
- (PT)** Exemplo de instalação
- (TR)** Kurulum örneği

schwarz
black
noir
negro
nero
preto
siyah

weiß
white
blanc
blanco
bianco
branco
beyaz

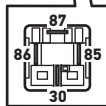

DE	Informationstext	15
EN	Information Text	15
FR	Texte d'information	16
ES	Texto informativo	16
IT	Informazioni	17
PT	Texto informativo	17
TR	Bilgi Metni	18

DE TECHNISCHE DATEN

	Nennspannung	Spannungsbereich	Eingangswerte	Zulässige Umgebungstemperatur	Schutzklasse
357 206-011 / 041	12 V	12V-30V	1,2A, 13,5W	-40° C bis +50° C	IP 67
	24V		0,6A, 13,4W		
357 206-031 / 051	12 V		1,2A, 13,5W		
	24V		0,6A, 13,4W		

Der Betrieb der Leuchte mit Wechselspannung ist nicht zulässig.

Eine Dimmung kann durch das regulierbare Tastverhältnis eines pulsweitenmodulierten Signals (PWM) realisiert werden. Dies kann durch Zwischenschalten eines herkömmlichen LED PWM-Dimmers in der Versorgungsleitung ermöglicht werden. (Frequenzbereich 100 - 1.000 Hz)

15

EN TECHNICAL DATA

	Nominal voltage	Range of voltage	Input values	Admissible ambient temperature	Class of protection
357 206-011 / 041	12 V	12V-30V	1,2A, 13,5W	-40°C up to +50°C	IP 67
	24V		0,6A, 13,4W		
357 206-031 / 051	12 V		1,2A, 13,5W		
	24V		0,6A, 13,4W		

Operation of the light with alternating voltage is not permitted!

Dimming can be achieved by means of an adjustable duty cycle of a pulse width-modulated signal (PWM).

This can be facilitated by interconnecting a conventional LED

PWM dimmer in the supply line. (Frequency range 100 - 1,000 Hz)

	Tension nominale	Plage de tension	Valeurs d'entrée	Température ambiante admissible	Classe de protection
357 206-011 / 041	12V	12V-30V	1,2A, 13,5W	-40°C à +50°C	IP 67
	24V		0,6A, 13,4W		
357 206-031 / 051	12V		1,2A, 13,5W		
	24V		0,6A, 13,4W		

Le fonctionnement du luminaire avec une tension alternative n'est pas admis.

Le réglage de la luminosité peut être obtenu par la variation du rapport cyclique d'un signal à modulation à largeur d'impulsion (MLI / PWM).

Ceci est rendu possible en intercalant un variateur MLI à LED classique dans le câble d'alimentation. (Plage de fréquence 100 - 1 000 Hz)

	Tensión nominal	Margen de tensión	Valores de entrada	Temperatura ambiente admisible	Clase de protección
357 206-011 / 041	12V	12V-30V	1,2A, 13,5W	-40°C hasta +50°C	IP 67
	24V		0,6A, 13,4W		
357 206-031 / 051	12V		1,2A, 13,5W		
	24V		0,6A, 13,4W		

No está permitido el uso del faro con tensión alterna.

Puede atenuarse la iluminación mediante un ciclo de trabajo que regule la señal digital de modulación por impulsos (PWM).

Esto puede conseguirse interconectando un regulador convencional PWM LED en el cable del suministro. (Rango de frecuencia 100 - 1.000 Hz)

IT DATI TECNICI

	Tensione nominale	Intervallo di tensione	Valori di ingresso	Temperatura ambiente ammessa	Categoria di protezione
357 206-011 / 041	12V	12V-30V	1,2A, 13,5W	da -40°C a +50°C	IP 67
	24V		0,6A, 13,4W		
357 206-031 / 051	12V		1,2A, 13,5W		
	24V		0,6A, 13,4W		

Il funzionamento del fanale con tensione alternata non è consentito.

Grazie al duty cycle regolabile di un segnale a modulazione d'ampiezza d'impulso (PWM) è possibile eseguire un'attenuazione.

Questo è possibile inserendo in serie nel cavo di alimentazione un comune dimmer PWM per LED.

(Gamma di frequenza: 100 - 1000 Hz)

PT DADOS TÉCNICOS

	Tensão nominal	Gama de tensão	Valores de entrada	Temperatura ambiente admissível	Classe de proteção
357 206-011 / 041	12V	12V-30V	1,2A, 13,5W	-40°C ... +50°C	IP 67
	24V		0,6A, 13,4W		
357 206-031 / 051	12V		1,2A, 13,5W		
	24V		0,6A, 13,4W		

O funcionamento da luz com tensão alternada não é permitido!

A escurecimento pode ser alcançado por meio de um ciclo de trabalho ajustável de um sinal modulado por impulsos (PWM).

Isto pode ser facilitado através da interligação de um LED convencional

PWM dimmer na linha de abastecimento. (Gama de frequências 100 - 1.000 Hz)

	Nominal gerilim	Gerilim aralığı	Giriş değerleri	İzin verilen ortam sıcaklığı	Koruma sınıfı
357 206-011 / 041	12V	12V-30V	1,2A, 13,5W	-40°C ... +50°C	IP 67
	24V		0,6A, 13,4W		
357 206-031 / 051	12V		1,2A, 13,5W		
	24V		0,6A, 13,4W		

Işığın alternatif gerilimle çalıştırılmasına izin verilmez!

Karartma, darbe genişlik modülasyonlu bir sinyalin (PWM) ayarlanabilir bir görev döngüsü aracılığıyla gerçekleştirilebilir.

Bu, geleneksel bir LED'i birbirine bağlayarak kolaylaştırılabilir

Besleme hattında PWM dimmer. (Frekans aralığı 100 - 1.000 Hz)

DE Beleuchtungsanlage auf einwandfreie Funktion hin prüfen

EN Check that the lighting system is working perfectly

FR Contrôler le bon fonctionnement de l'installation d'éclairage

ES Comprobar que el sistema de iluminación funciona impecablemente

IT Controllare la perfetta funzionalità dell'impianto di illuminazione

PT Verifique que o sistema de iluminação está a funcionar bem.

TR Aydınlatma sisteminin mükemmel çalıştığını kontrol edin.

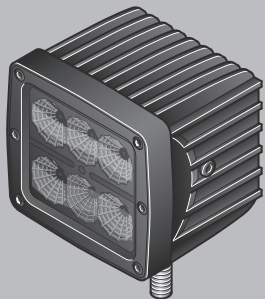

HELLA GmbH & Co. KGaA

Rixbecker Straße 75

59552 Lippstadt /Germany

www.hella.com

© HELLA GmbH & Co. KGaA, Lippstadt

460 000-67 /06.24